

realcold Milk Vats

Air-Cooled Condensing Units

RMV Units Custom Designed & Built for
On-Farm Refrigeration



realcold
People
Product
Partnerships

Air-Cooled Condensing Units

Applications

- These units have been specifically developed for on-farm refrigeration of milk vats.

Features

- Single, Twin or Triple multiplexed compressors offering staged capacity control over a wide range of applications.
- 6 sizes, covering capacities from 11 to 36 Kw.
- ASERCOM compressor certification, assuring independent verification of published performance capacity figures.
- Horizontal air flow.
- Performance rated at up to 55 degrees condensing temperature.

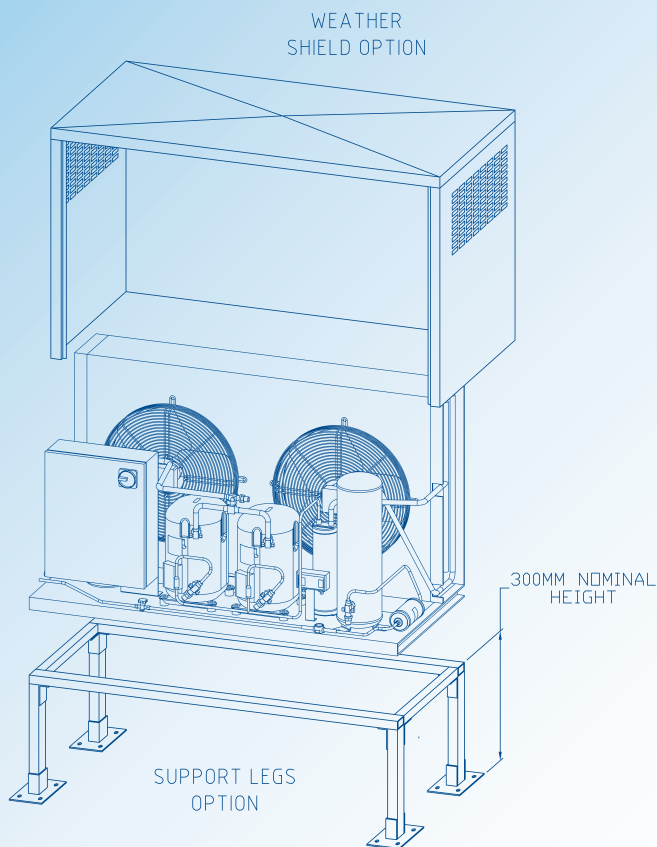

ADDITIONAL OPTIONS

- Desuperheater plate heat exchanger for water heat recovery. Leaving water temperature of up to 60°C or greater can be achieved.
- Chilled water heat exchanger kit for pre chilling milk. Apply to Technical Department for details.
- 300mm high extended support legs (refer to image on the left).
- Optional Weather Shield for outdoor use.

See next page for further details

COMPRESSOR

- Each high efficiency hermetic type compressor is hermetically sealed, quiet running and supported on rubber mounts to minimise vibration.

COOLING CAPACITY

- Cooling Capacity Rated @ 2°C SST / 45°C SCT / 32°C Ambient on R404A refrigerant.

REFRIGERATION PIPING

- The standard unit allows for a line length of up to 30m.

WIRING

- Electrical supply required (including voltage fluctuation limits): 3 phase 342-436 V a.c. 50 Hz with neutral and earth. A control panel located in the outdoor unit is fully wired, ready to accept the main power supply.

SAFETY Features

- HP / LP switch and an anti rapid cycle timer for compressor protection. The compressor also has internal overload protection.
- Circuit breaker control circuits.

Unit Selection Guide

Model	Nominal Duty kW	Nominal Herd Size	Vat Size for Daily Pickup
RMV450	11.4	250 cows	5700 litres
RMV600	15.1	300 cows	6800 litres
RMV900	22.0	400 cows	9100 litres
RMV1000	25.1	500 cows	12000 litres
RMV1200	31.9	550 cows	15000 litres
RMV1500	36.3	900 cows	21500 litres

Nominal Capacities @ 2°C SST/ +45°C SCT R404a

All models are 380-415V 3PH 50Hz

Nominal Herd and Vat Sizes based on:

- 22 Lt/cow per day
- 55% morning, 45% afternoon milking
- Nominal 4 hour pulldown (3 hour from completion of milking)
- Milk $\Delta T = 13^{\circ}\text{C}$

NOTE: Materials and specifications are subject to change without notice due to ongoing research and development program

Additional Options

Water Heating Options

Realcold Stock No. Normal Desuperheaters	Realcold Stock No. Full Size Desuperheaters	Model	Hot Water Heating Capacity kW*
OHC15-20	OMC60-20	RMV 450	5
OHC15-20	OMC60-20	RMV 600	6.3
OHC15-20	OMC60-20	RMV 900	8.3
OHC15-20	OMC60-30	RMV 1000	11
OHC15-20	OMC60-30	RMV 1200	12.4
OHC15-30	OMC60-40	RMV 1500	18.2

Weather Shield Options

Realcold Stock No.	Description
C1940	Easypack W/Shield RMTZ112-150
C1941	Easypack W/Shield RMTZ175-X300
C1942	Easypack W/Shield RMTZX450-600
C1943	Easypack W/Shield ZX900T-1200T
C1944	Easypack W/Shield RMTZX1500T

- Full Desuperheater duties based on EWT 20°C LWT 60°C on R404a refrigerant.
- Normal Desuperheater duties based on EWT 20°C LWT 40°C on R404a refrigerant."

Support Leg Options

Realcold Stock No.	Description
D0175	Realcold Corner Leg
D0176	Realcold Centre Leg



Specifications

REALCOLD RMV450 & 600

DESCRIPTION	RMV450	RMV600
Base Unit	RMTXZ450	RMTXZ600
Compressor - Tecumseh	TAG4553Z	TAG4573Z
Nominal Horsepower	4.5	6.25
Cooling Capacity *	11.4 kW	15.1 kW
Power Supply	380-420V 3PH 50Hz	380-420V 3PH 50Hz
Compressor	Run Amps	12.35 A
	Starting Amps	19.0 A
Condenser Fan	2 x 220-240V 0.8A 1PH 50Hz	2 x 220-240V 0.8A 1PH 50Hz
Weight Approx (dry)	118 Kg	135 Kg
Recommended Pipe Sizes	22mm (12mm)	22mm (12mm)

* Cooling Capacity Rated @ 2°C SST / 45°C SCT / 32°C Ambient on R404A refrigerant

Diagrams

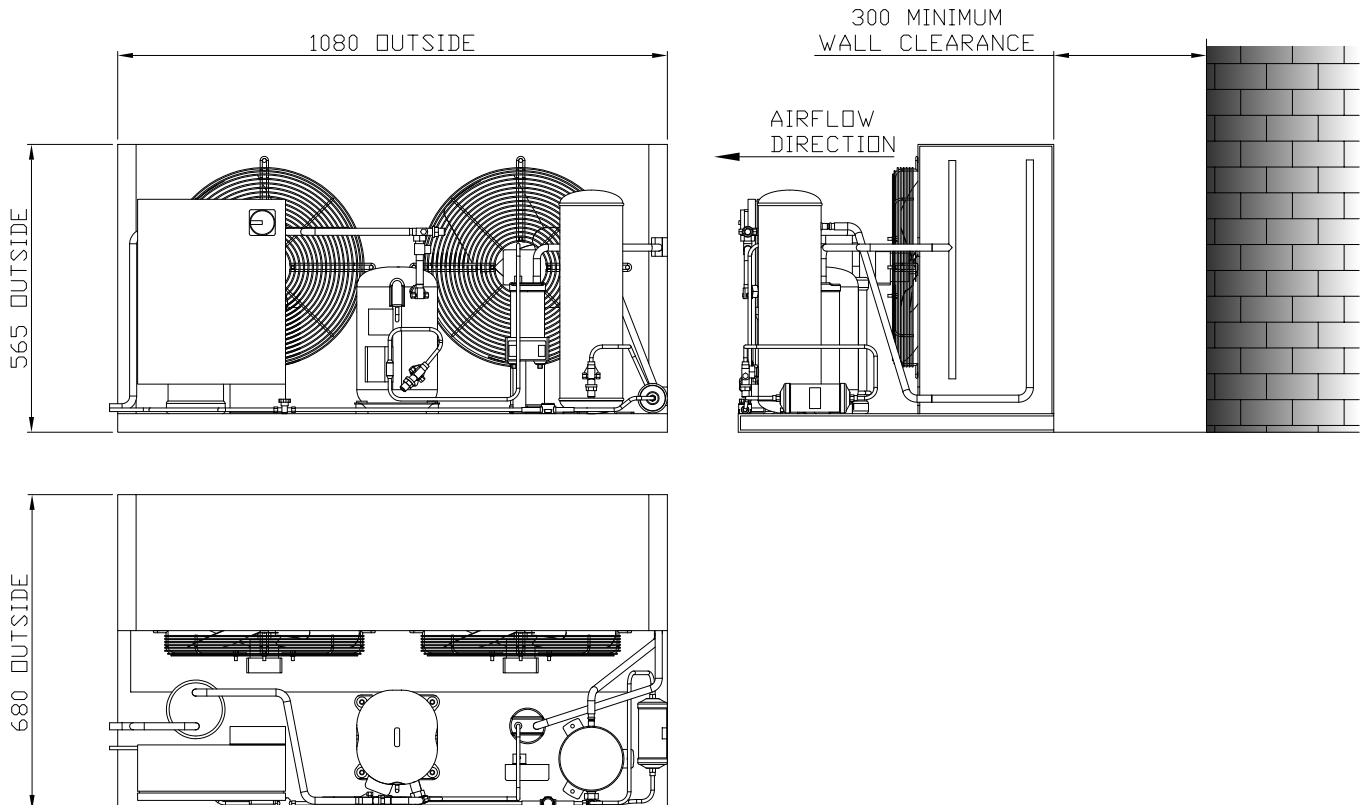

Specifications

REALCOLD RMV900 & 1000

DESCRIPTION	RMV900	RMV1000
Base Unit	RMTXZ900T	RMTXZ1000T
Compressor - Tecumseh	2 x TAGP4553Z	2 x TAGP4561Z
Nominal Horsepower	9	10
Cooling Capacity *	22.0 kW	25.1 kW
Power Supply	380-415V 3PH 50Hz	380-415V 3PH 50Hz
Compressor Run Amps	16.2 A	19.5 A
Starting Amps	25.5 A	25.5 A
Condenser Fan	2 x 380V 0.9A 3PH 50Hz	2 x 380V 0.9A 3PH 50Hz
Weight Approx (dry)	213 Kg	218 Kg
Recommended Pipe Sizes	28mm (16mm)	28mm (16mm)

* Cooling Capacity Rated @ 2°C SST / 45°C SCT / 32°C Ambient on R404A refrigerant

Diagrams

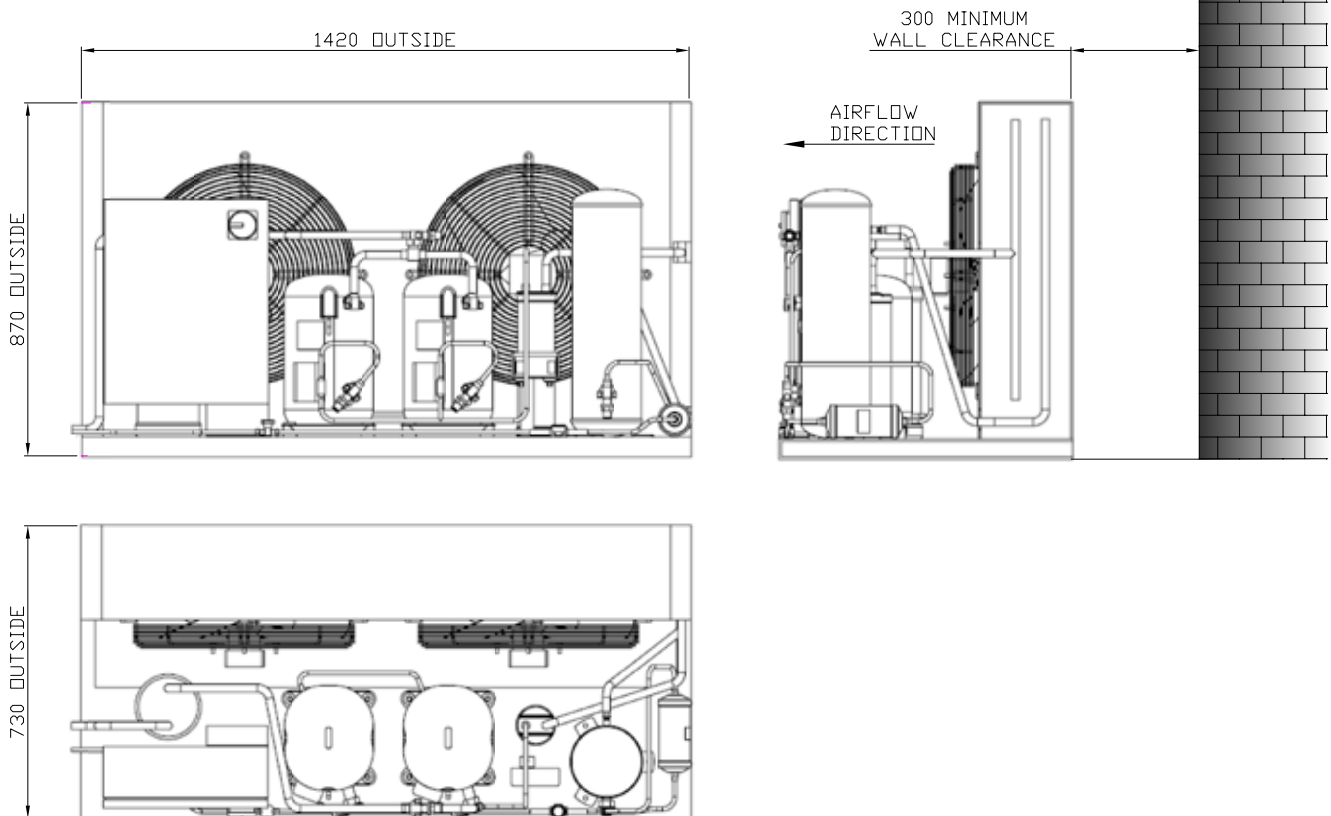

Specifications

REALCOLD RMV1200

DESCRIPTION		RMV1200
Base Unit		RMTXZ1200T
Compressor - Tecumseh		2 x TAGP4573Z
Nominal Horsepower		12
Cooling Capacity *		31.9 kW
Power Supply		380-415V 3PH 50Hz
Compressor	Run Amps	23.9 A
	Starting Amps	39.0 A
Condenser Fan Amps		2 x 380V 0.9A 3PH 50Hz
Weight Approx (dry)		218 Kg
Recommended Pipe Sizes		28mm (16mm)

* Cooling Capacity Rated @ 2°C SST / 45°C SCT / 32°C Ambient on R404A refrigerant

Diagrams

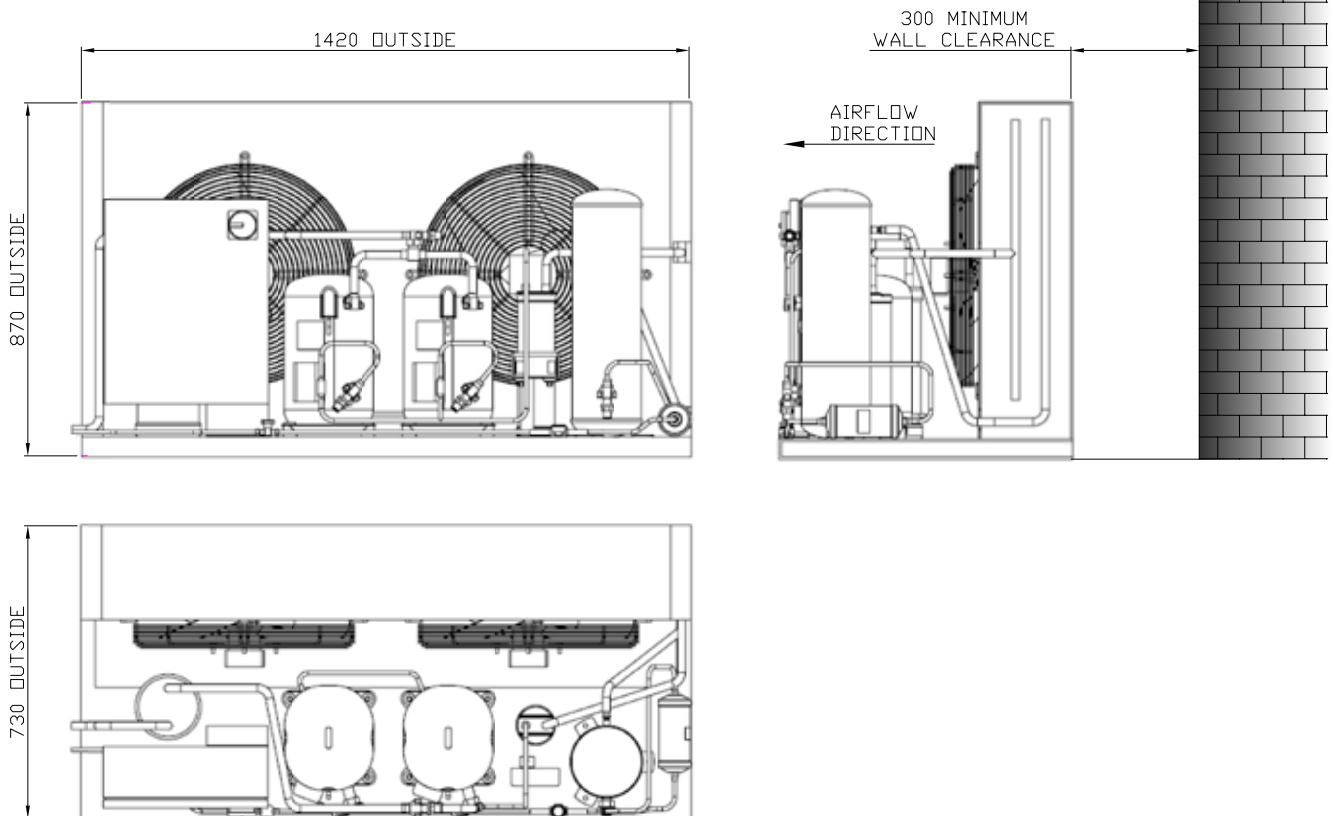

Specifications

REALCOLD RMV1500

DESCRIPTION		RMV1500
Base Unit		RMTXZ1500T
Compressor - Tecumseh		3 x TAGP4561Z
Nominal Horsepower		15
Cooling Capacity *		36.3 kW
Power Supply		380-415V 3PH 50Hz
Compressor	Run Amps	27.0 A
	Starting Amps	153.0 A
Condenser Fan Amps		2 x 380V 0.9A 3PH 50Hz
Weight Approx (dry)		300 Kg
Recommended Pipe Sizes		28mm (16mm)

* Cooling Capacity Rated @ 2°C SST / 45°C SCT / 32°C Ambient on R404A refrigerant

Diagrams

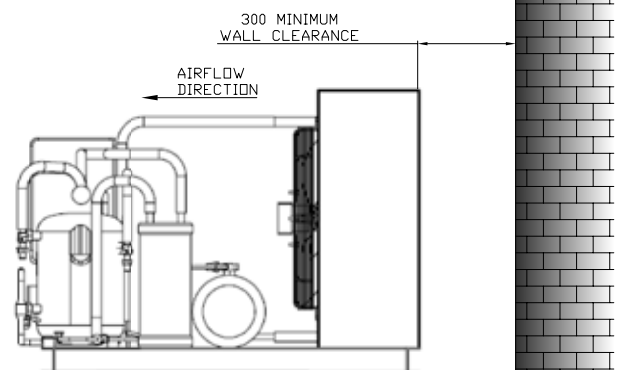
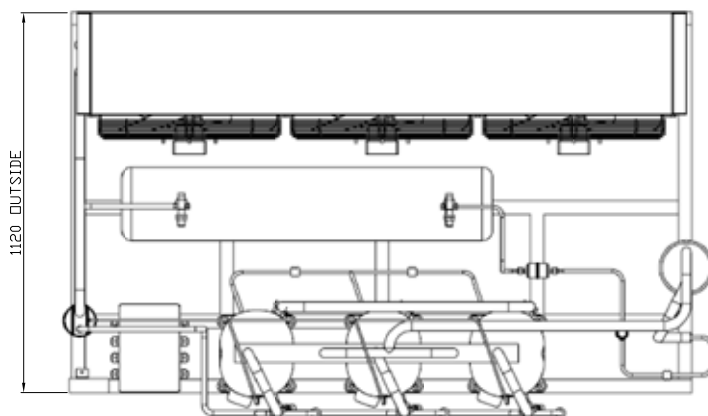
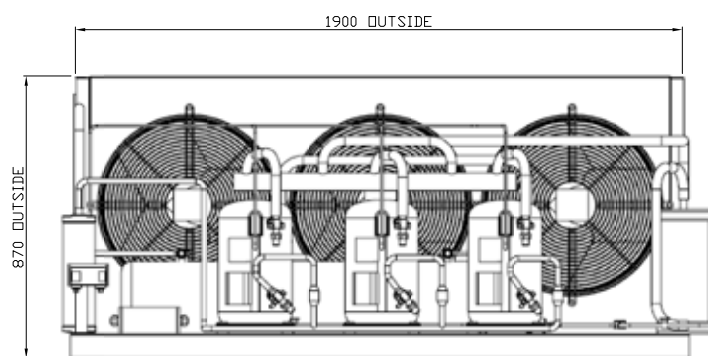

AUCKLAND BRANCH / HEAD OFFICE

9 Prescott Street, Penrose 1061
PO Box 12072, Penrose 1642
Orders Direct Fax: 09 526 5748
Phone: 09 526 5700
Fax: 09 526 5721
Email: parts@realcold.co.nz

NORTH HARBOUR

Unit C, 28 Canaveral Drive, Albany 0632
PO Box 305354, Triton Plaza
North Shore City 0757
Phone: 09 477 0274
Fax: 09 478 2309
Email: nh@realcold.co.nz

WHANGAREI / NORTHLAND

Unit A1, 7 - 11 Nell Place, Raumanga,
Whangarei 0110
PO Box 25056, Whangarei Mail Centre
Whangarei 0148
Phone: 09 430 4476
Fax: 09 430 7465
Email: nl@realcold.co.nz

HAMILTON

43 Lake Road, Frankton, Hamilton 3204
PO Box 5238, Frankton, Hamilton 3242
Phone: 07 848 2111
Fax: 07 848 2333
Email: hm@realcold.co.nz

TAURANGA

5 Barberry Street, Judea, Tauranga 3110
PO Box 15610, Tauranga 3144
Phone: 07 571 0096
Fax: 07 571 0097
Email: tga@realcold.co.nz

PALMERSTON NORTH

Unit 2, 597-599 Tremaine Ave,
Palmerston North 4410
PO Box 4368, Manawatu Mail Centre,
Palmerston North 4442
Phone: 06 357 9101
Fax: 06 357 9103
Email: pn@realcold.co.nz

HAWKES BAY / HASTINGS

Cnr St Aubyn Street East & Miller Street,
Hastings 4122
PO Box 488, Hastings 4156
Phone: 06 870 3714
Fax: 06 870 3726
Email: hbn@realcold.co.nz

WELLINGTON

54 Fitzherbert Street, Petone,
Lower Hutt 5012
PO Box 38527, Wellington Mail Centre,
Lower Hutt 5045
Phone: 04 569 3072
Fax: 04 568 2210
Email: wgtm@realcold.co.nz

CHRISTCHURCH

71 Harman Street, Addington,
Christchurch 8024
PO Box 9150, Tower Junction,
Christchurch 8149
Phone: 03 338 8084
Fax: 03 338 9938
Email: chch@realcold.co.nz

DUNEDIN

18 Roberts Street, Dunedin 9016
PO Box 2536, Dunedin 9044
Phone: 03 467 7106
Fax: 03 467 7107
Email: dn@realcold.co.nz



Orders Phone 0800 11 66 90

www.realcold.co.nz

Realcold Limited reserves the right to
change specifications without notice.
© Realcold Limited, VI, May 2011

realcold
People
Product
Partnerships